



# 承 认 书

## SPECIFICATION FOR APPROVAL

客户名称  
Customer name

---

客户料号  
Customer material No.

---

产品名称  
Product name

BMF 6.35\*32 陶瓷保险丝

---

产品型号  
Product model

---

送样日期  
Deliver date

年 月 日

---

### 本司确认 (TRX APPROVAL)

检验 Inspection	校对 Proofreading	批准 Approval	签章 Signature
唐军	唐盛华	陈忠	

### 客户确认 (CUSTOMER APPROVAL)

检验 Inspection	校对 Proofreading	批准 Approval	签章 Signature

确认结果 Verify the results:

合格 Qualified       不合格 Unqualified       其他 Other

# 规格承认书

## Specification for approval

产品名称: **BMT 系列 慢断型 陶瓷管保险丝**

**Product Type: BMT Series Time -Acting Ceramic Tube Fuse**

东莞市奥力特电子科技有限公司

**Dongguan Aolittel Electronics Technology co., Ltd**

电话: +86-769-38935409 传真: +86-769-38935409

厂址: 广东省东莞市大岭山镇金榄岭街 27 号

网址: <http://www.aolittel.com>



## 目录 Contents

1. 适用范围 / Scope of Application.....	4
2. 安规认证标准及编号 / Standards and Agency Approvals.....	4
3. 产品标示 / Product Marking.....	5
4. 外观及形状 / Appearances and Configuration.....	6
5. 结构及尺寸 / Dimensions and Structure.....	6
6. 材料明细 / Material Details.....	7
7. 产品特性 / Product Characteristics.....	7
8. 电气特性 / Electrical Characteristics.....	7
9. 环境特性 / Environmental Characteristic.....	8
10. 安装建议 / Installation Recommendations.....	
11. 包装 / Packaging.....	9
12. 其他 / Others.....	10

## 1. 适用范围 / Scope of Application

本产品适用于各类电子设备电路的过流保护作用, 广泛应用于照明设备、电源设备、仪器仪表以及适配器等领域。

This product is suitable for various kinds of electronic devices' circuit over current protection. Widely used in industrial of Lighting, Power supply, Instrument, Digital multimeter and Adapter applications, etc.

## 2. 安规认证标准及编号 / Standards and Agency Approvals

2.1 执行标准: 遵循 UL 248 -1 / -14。

Standards: In accordance with UL 248 -1 / -14.

2.2 认证范围 Certification:

额定电压 Voltage Rating	安规标准 Agency	认证范围 Ampere Range	证书编号 Agency File Number
250V	c UR us	100mA ~ 50A	E340427
	cUL	100mA ~ 50A	E340427

2.3 目录编号 Catalogue No., A=250V , ● 已认证 Approved / ○ 认证中 Pending

目录编号 Catalog No.	额定电流 Ampere Rating	额定电压 Voltage Rating	分断能力 Breaking Capacity	熔化热能 I <sup>2</sup> TMelting Integral(A <sup>2</sup> .S)	安规认证 Agency Approvals			
BMT0100A	100mA	250V	1000A@250VAC/DC (100mA~50A);	0.003	●	●	○	○
BMT0160A	160mA	250V		0.008	●	●	○	○
BMT0200A	200mA	250V		0.02	●	●	○	○
BMT0250A	250mA	250V		0.026	●	●	○	○
BMT0300A	300mA	250V	1500A@250V AC/DC (100mA~12A);	0.047	●	●	○	○
BMT0315A	315mA	250V		0.055	●	●	○	○
BMT0350A	350mA	250V		0.072	●	●	○	○
BMT0400A	400mA	250V		0.10	●	●	○	○
BMT0500A	500mA	250V		0.16	●	●	○	○
BMT0600A	600mA	250V		0.25	●	●	○	○

BMT0630A	630mA	250V	1000A@250VAC/DC (100mA~50A);	0.28	●	●	○	○
BMT0750A	750mA	250V		0.49	●	●	○	○
BMT0800A	800mA	250V		0.60	●	●	○	○
BMT1100A	1A	250V		0.8	●	●	○	○
BMT1125A	1.25A	250V		1.6	●	●	○	○
BMT1150A	1.5A	250V		2.5	●	●	○	○
BMT1160A	1.6A	250V		3.2	●	●	○	○
BMT1200A	2A	250V		5.6	●	●	○	○
BMT1250A	2.5A	250V		7.6	●	●	○	○
BMT1300A	3A	250V		14	●	●	○	○
BMT1315A	3.15A	250V		19	●	●	○	○
BMT1350A	3.5A	250V		20	●	●	○	○
BMT1400A	4A	250V		25	●	●	○	○
BMT1500A	5A	250V		42	●	●	○	○
BMT1600A	6A	250V		80	●	●	○	○
BMT1630A	6.3A	250V		96	●	●	○	○
BMT1800A	8A	250V	200	●	●	○	○	
BMT2100A	10A	250V	320	●	●	○	○	
BMT2120A	12A	250V	470	●	●	○	○	
BMT2150A	15A	250V	650	●	●	○	○	
BMT2160A	16A	250V	680	●	●	○	○	
BMT2200A	20A	250V	870	●	●	○	○	
BMT2250A	25A	250V	1320	●	●	○	○	
BMT2300A	30A	250V	1720	●	●	○	○	
BMT2400A	40A	250V	1880	●	●	○	○	
BMT2500A	50A	250V	2020	●	●	○	○	

### 3. 产品标示 / Product Marking

保险丝管体上需有下列标示。

The fuses body shall have the following markings.

示例 Example:

② Series	50A	250V	CU <sup>®</sup> US
①	②	③	④

①	系列型号名称/Series Type Name: ② Series (快断型/Fast-Acting)
②	额定电流/Rated Current (A): <u>50 A</u> 或 or <u>mA</u>
③	额定电压/Rated Voltage (V): <b>250V</b>
④	认证符号/ Approval Marks: CU <sup>®</sup> US

**注意 / Note:** 对于标示的大小和位置没有规定，侵权必究。

*Size and position of the markings shall not be provided, all right reserved.*

特殊问题请咨询有关人员,关于引脚直径有 1.2mm 和 1A 以下未进沙 *Special problem please consult the relevant personnel, about the pin diameter is 1.2 mm and 1 a below into the sand*

关于有引脚和无引脚请用文字表示或用=有字母+P= (有引脚) 无字母+P= (表示无引脚)

*About with and without pin pin please use = have expressed in words or letters + P = no letters (pin) + P = no pin (say)*

#### 4. 外观及形状 / Appearances and Configuration

4.1 外观不应出现显著的污点、裂纹，标识应该容易辨识。

There shall not be any remarkable stain and crack on the appearances, markings shall be easily legible.

4.2 形状：带直线引脚和无引脚小型陶瓷管保险丝。

Configuration: No pin/Axial Leaded Miniature Ceramic Tube Fuse.

#### 5. 结构及尺寸 / Dimensions and Structure

单位：毫米 / Unit: mm

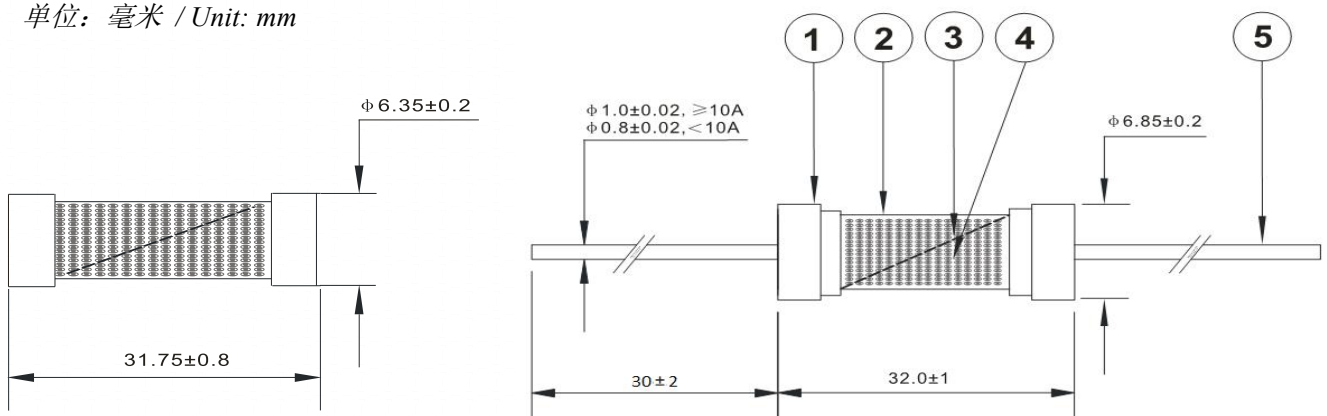

## 6. 材料明细 / Material Details

编 号 NO.	零 件 名 称 Part Name	材 质 Material
①	铜帽 Cap	黄铜镀镍 Nickel Plated Brass
②	陶瓷管 Body	非透明陶瓷管 Non-Transparent Ceramic Tube
③	熔丝 Fuse element	合金 Alloy
④	防爆砂 Explosion-proof sand	石英砂 Quartz sand
⑤	引线 Lead wire	镀锡铜线 Tin Plated Copper

## 7. 产品特性 / Product Characteristics

### 7.1 引脚拉力强度 / Lead Pull Strength

5 牛顿 10±1 秒 / 5N for 10±1 Seconds

### 7.2 引脚推力强度 / Lead Thrust Strength

2 牛顿 10±1 秒 / 2N for 10±1 Seconds

### 7.3 可焊性 / Solder ability

波峰焊/Wave : 260℃, ≤3s;

烙铁焊/Soldering Iron: 350±10℃, ≤3s.

### 7.4 耐焊接热 / Soldering Heat Resistance

波峰焊/Wave : 260℃, 10s;

烙铁焊/Soldering Iron: 350℃, 5s.

## 8. 电气特性 / Electrical Characteristics

### 8.1 实验条件: Test Condition

所有测试环境温度均为  $25 \pm 5^\circ\text{C}$ 。

All electrical test is to be conducted with the ambient air at a temperature of  $25 \pm 5^\circ\text{C}$ .

#### 8.2 负载能力 / Load capacity:

当保险丝通过 100% 的额定电流时，在 4 小时内不应熔断。

When the fuse loads through 100% of rated current, should blow within 4 hours.

#### 8.3 分断能力 / Interrupting Rating:

保险丝承受分断能力:

1000A@250V/AC/DC (100mA~50A);

1500A@250V AC/DC (100mA~12A);

Breaking Capacity:

1000A@250V/AC/DC (100mA~50A);

1500A@250V AC/DC (100mA~12A);

#### 8.4 温度上升试验 / Rising Temperature Test:

通 1.0 倍额定电流，当温度稳定时（5 分钟测量 4 次，且每次测量值与平均值相差不超过  $2^\circ\text{C}$ ）。测得熔断体任何部位的温升不得超过  $75^\circ\text{C}$ ，周围环境温度为  $25 \pm 5^\circ\text{C}$ 。

When the 100% times of Ampere Rating passes the fuse, after reaching thermal balance, the temperature on the fuse surface rising shall not be higher than  $75^\circ\text{C}$ . Note: Rising temperature = the Surface temperature - Ambient temperature.

#### 8.4 熔断时限 / Operating Characteristics

额定电流的% % of Ampere Rating(In)	熔断时间 Blowing Time
100%* In	大于 4 小时(4 hours Min)
200%* In	小于 60 秒(60 sec Max)

### 9. 环境特性 / Environmental Characteristic

#### 9.1 使用温度范围 / Operating Temperature

$-55^\circ\text{C} \sim +125^\circ\text{C}$ 。

#### 9.2 保存条件 Stock Condition

湿度：相对湿度  $\leq 75\%$  平均可以存放 3 年。



Humidity: Relative humidity  $\leq$  75% store 3 years in average.

- 9.3 若操作环境温度超出  $25 \pm 5^\circ\text{C}$  范围, 在选用保险丝规格时, 需考虑操作环境温度对保险丝的影响, 请参照如下: 温度-电流曲线图。

When choosing the fuse's specification, if the operating environmental temperature beyond the scope from  $20 \sim 30^\circ\text{C}$ , engineer should consider the environmental temperature's affection to fuses. Please refer: Temperature Rerating Curve:

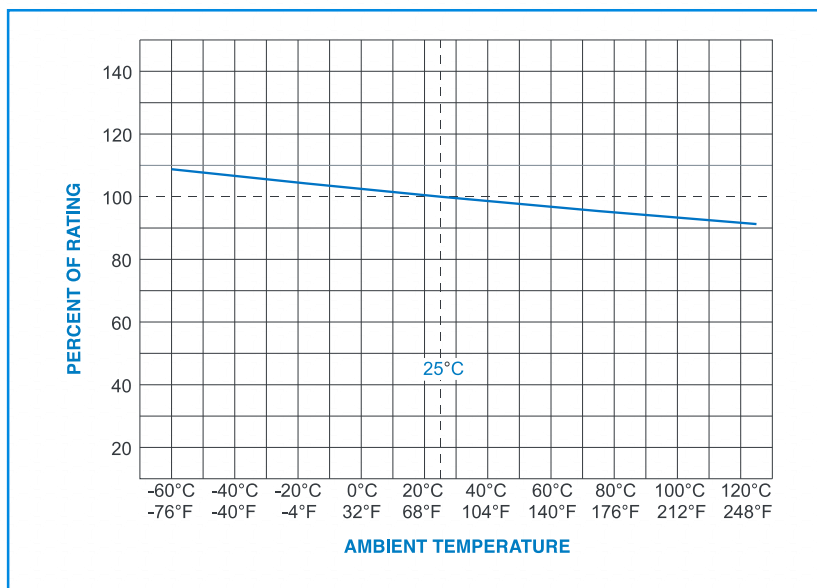

## 10. 建议焊接参数 / Recommended Soldering Parameters

### A. 波峰焊参数 / Wave Parameters:

锡炉温度 / Solder Pot Temperature:  $260^\circ\text{C}$  Max

焊接时间 / Solder Dwell Time: 2~5s

### B. 手工焊参数 / Hand-Solder Parameters:

烙铁温度 / Solder Iron Temperature:  $350 \pm 5^\circ\text{C}$

焊接时间 / Heating Time: 5s Max

## 10. 包装 / Packaging

### 11.1 包装袋/盒印明下列标示: / The following items indicated on the label:

产品料号、额定(电压、电流)、分断类型及安规名称。

Catalog number, ratings (voltage, current), interrupting type and safety mark.

包装材料均符合 RoHS/REACH/HF 的环保要求, 且包装材料不会和零件发生化学反应,

造成不良。

The packing material conforms to ROHS/REACH/HF environmental protection request. And the packing materials will not have the chemical reaction with the components.

### 11.2 包装数量 / Packing Quantity

每胶袋 200 个保险丝 / Bulk 200 pcs in per poly bag;

每 10 胶袋 1 个内盒 / 10 poly bags in per inner box;

每 4 个内盒 1 个外箱 / 4 inner boxes in per outer carton

### 11.3 包装箱尺寸 / Packing Size

单位：毫米 / Unit: mm

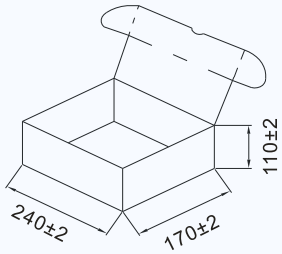
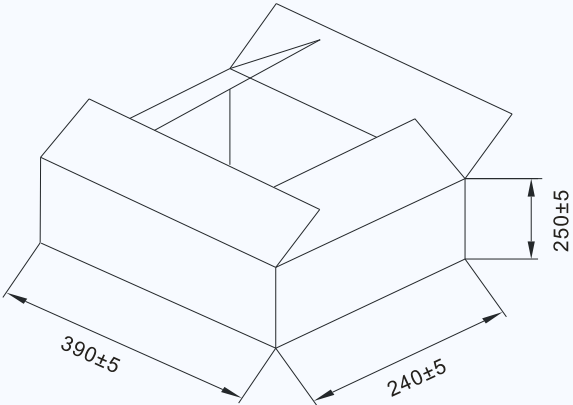
A. 内盒 Inner box:	B. 外箱 Outer carton:
L240±2 * W170±2 * H110±2	L390±5 * W240±5 * H250±5
	

## 11. 其他 / Others

12.1 如果在使用中有超出本规格书的要求，须经双方协商确认。

In the event that an impropriety is found beyond this specification, it shall be fixed by mutual agreement between the parties.

12.2 如果本规格书有不适当的情况，须通过双方协商并由本公司修改。

In the event that an impropriety is found in this specification, *AOLITTEL ELECTRONICS TECHNOLOGY CO., LTD.* shall amend it by mutual agreement between the parties.

### 附件 I: 安规证书 / Appendix I: Safety approval certificates